



MITYLITE™

Reveal High Capacity Cart

3072, 3096, 3672, 3696

ASSEMBLY INSTRUCTION SHEET

Supply List

Before beginning cart assembly, ensure that all of the following components and fasteners are included in the package.

Parts:

1. Handle with Covers (2)
2. Base
3. Removable Front Post with Covers & Caps (2)
4. Rear Support with Covers (2)
5. Rear Support Strap (4 holes)
6. Diagonal Brace with Neoprene (2)
7. (6) 5/16-18 X 1" Carriage Bolts
8. (8) 3/8-16 X 3/4" Socket Head Bolts
9. (6) 5/16-18 Nylock Nuts
10. (6) 5/16 Flat Washers

Tools Required:

1. 1/2" Wrench/Ratchet & Socket (not included)
2. 5/16" Hex Wrench (included)

Notes:

1. We recommend at least two people assemble this cart.
2. DO NOT tighten bolts until cart is completely assembled, this allows for adjustment, if necessary.
3. All bolts should be kept tight for the cart to function properly and to avoid a potentially dangerous situation.
4. Front Posts MUST be used to hold the tables on the cart.

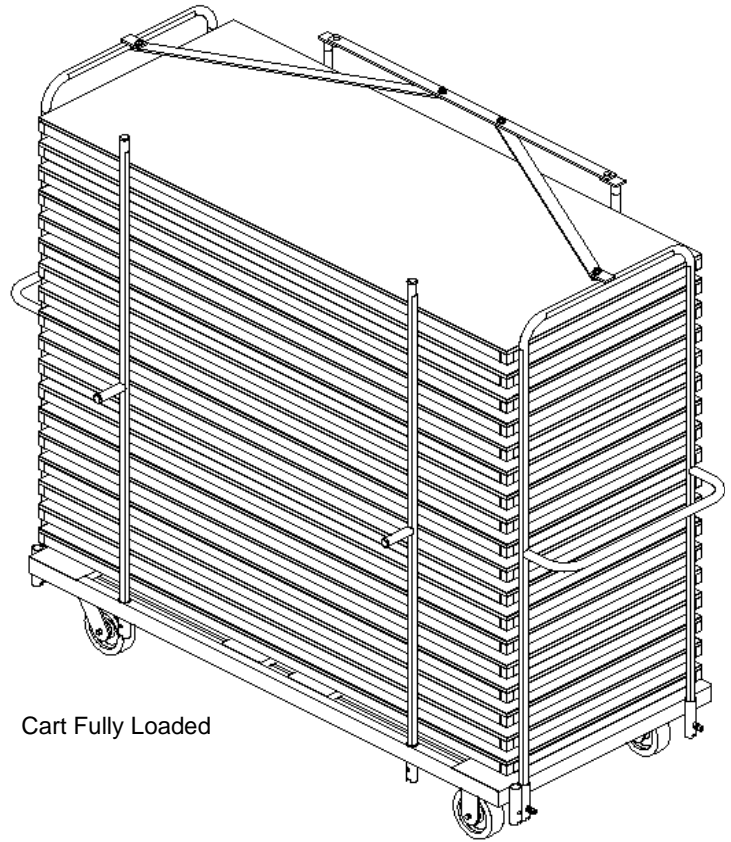

Cart Fully Loaded

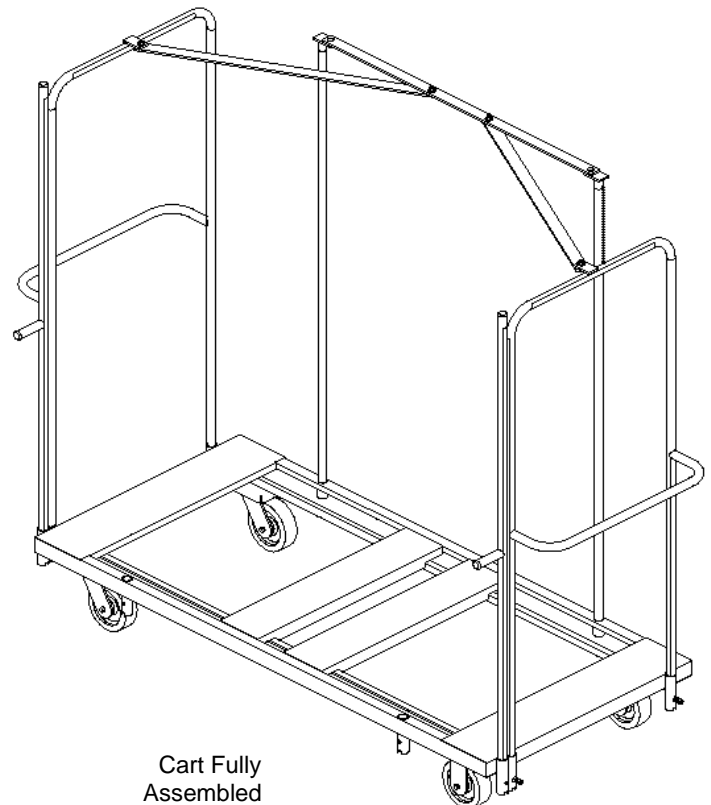
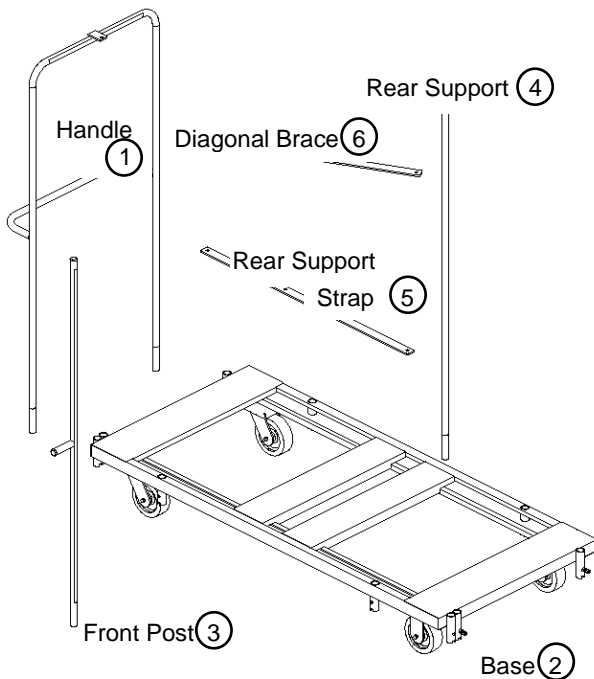

Cart Fully Assembled

Assembly Instructions

Step:

1. Lay the Base so that the casters are on the floor. Lock the brake on the swivel casters.
2. Insert the Handles on each end of the Base into the sockets WITH screws (See Figure 1).
3. Insert the Rear Supports into the sockets WITH screws on the back side of the Base. The long part of the Rear Support tabs MUST face each other (See Figure 1).
4. Insert the Front Posts into the sockets without screws on the end of the Base next to the Handles (See Figure 1).
5. Attach the Rear Support Strap to the Rear Supports (See Figure 2, Detail A) using 2 5/16" Carriage Bolts, washers, & nyloc nuts. Bolts must be inserted from the top. Hand tighten.
6. Attach one Diagonal Brace (with Neoprene facing the floor) to the underside of the Handle & Rear Support Strap (See Figure 3, Detail B) using 2 5/16" Carriage Bolts, washers, & nyloc nuts. Bolts must be inserted from the underside. Hand tighten.
7. Repeat Step 6 for other side of cart.
8. Tighten all bolts, securing handle & supports in place.

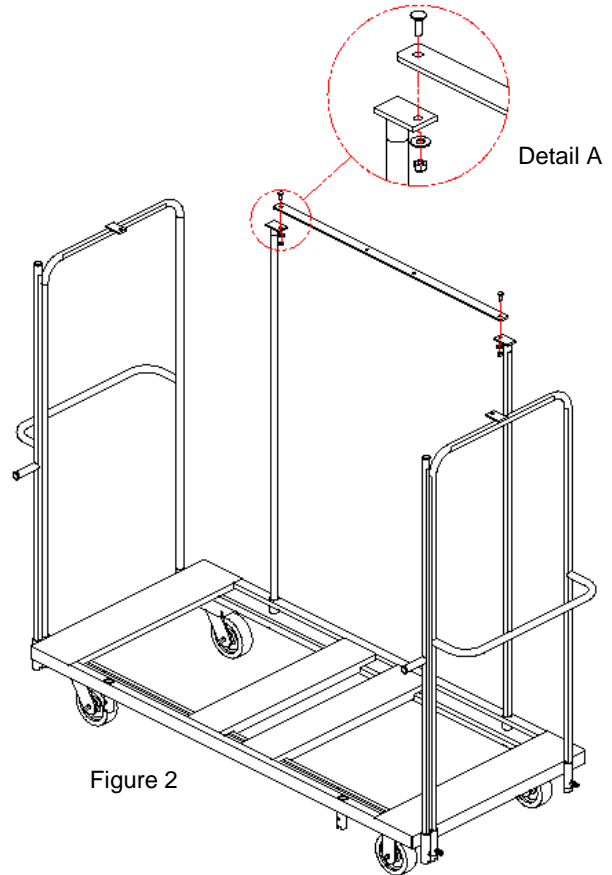

Figure 2

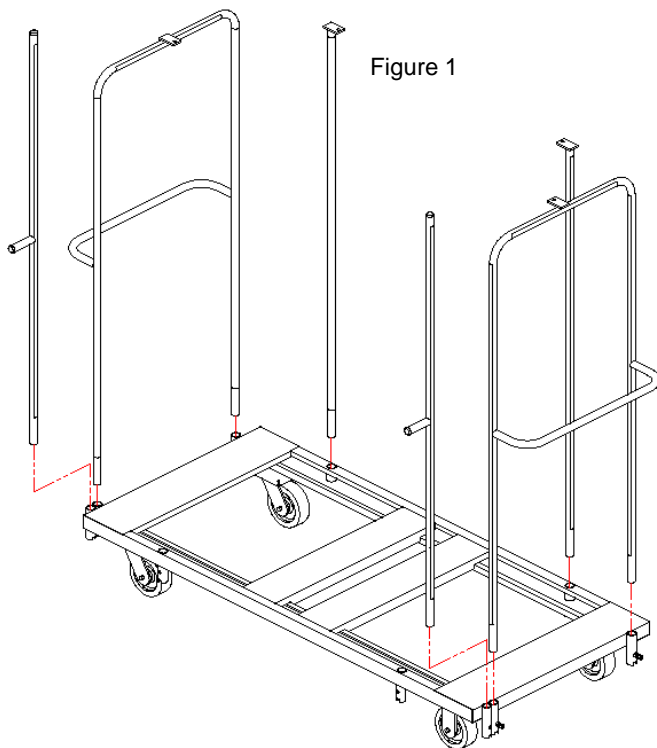

Figure 1

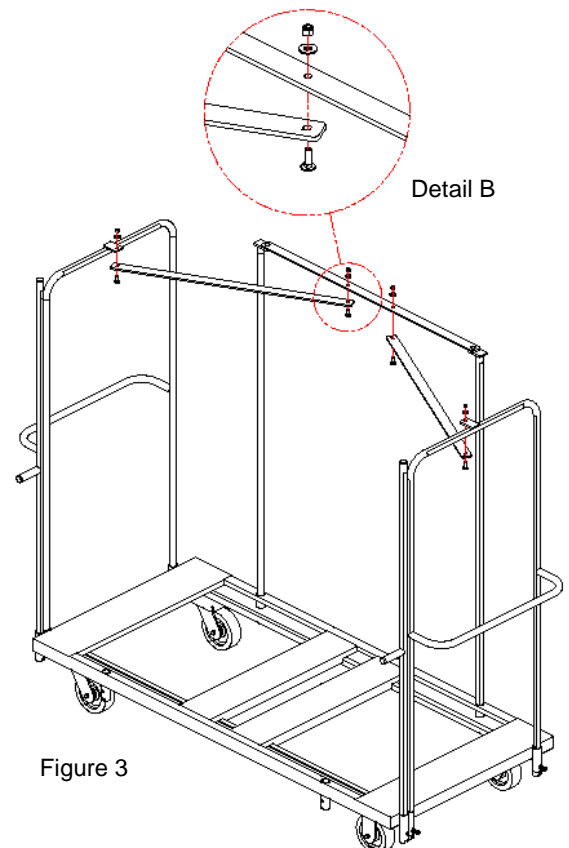

Figure 3