



# MITYLITE™

## RT Cart-Stacking

### ASSEMBLY INSTRUCTION SHEET

#### Supply List

Before beginning cart assembly, ensure that all of the following components and fasteners are included in the package.

#### Parts:

1. Base
2. Tension Bar
3. Ends (2)
4. Side Brace (4)
5. (18) 3/8"-16 X 1" Hex Bolts
6. (22) 3/8" Nyloc Nuts
7. (4) 3/8"-16 X 2 1/2" Hex Bolts
8. (8) 5/16"-18 Nyloc Nuts (to mount casters to caster pads)
9. (2) 6" Fixed Casters
10. (2) 6" Swivel Casters

#### Tools Required:

1. 1/2" Wrench, Ratchet & Socket (caster nuts) (not included)
2. 9/16" Wrench, Ratchet & Socket (not included)

#### Notes:

1. These instructions are used for all versions of the RT Stacking Cart.
2. We recommend at least two people assemble this cart.
3. **DO NOT** tighten bolts until cart is completely assembled, this allows for adjustment, if necessary.
4. This cart requires a forklift to transport.
5. If stacking this cart, **X-Base is required.**

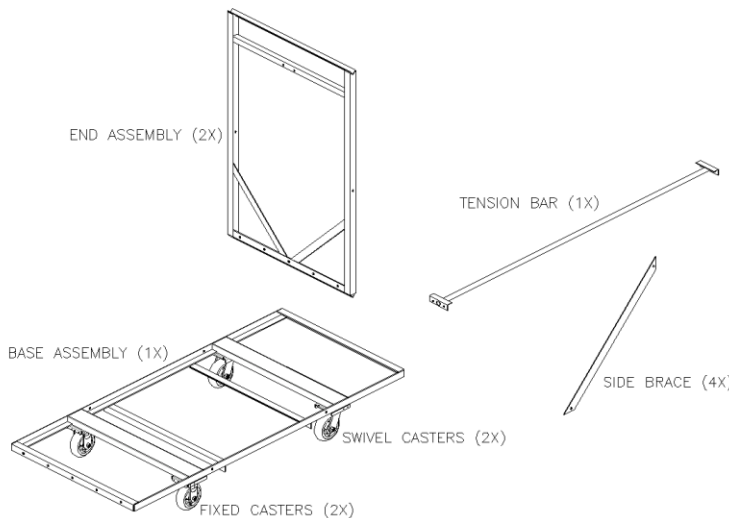
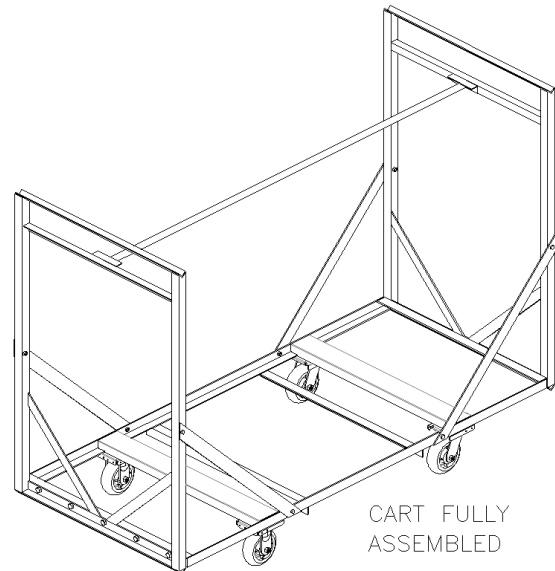
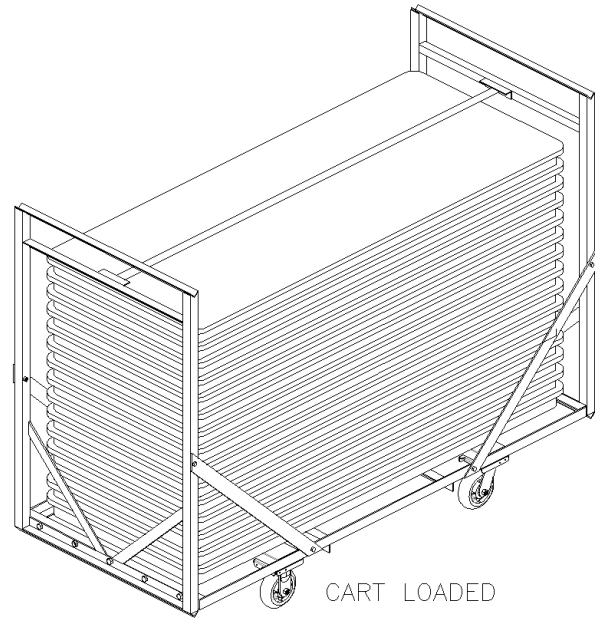

See other side for assembly instructions



### Assembly Instructions

#### Step:

1. Lay the Base upside down on a flat, level surface with the caster pads facing up (See Figure 1 for caster installation instructions). Tighten. Turn Base over to continue.
2. Attach the End Frames to the Base using the 1" long, 3/8" hex bolts and 3/8" nyloc nuts (See Figure 2, Detail A). Hand tighten.
3. Attach the Side Braces to the End Frames (See Figure 3, Detail B) using the 2 1/2" long, 3/8" hex bolts and 3/8" nyloc nuts, and to the Base (See Figure 3, Detail C) using the 1" long, 3/8" hex bolts and 3/8" nyloc nuts. Hand tighten.
4. Attach the Tension Bar to both End Frames using the 1" long, 3/8" hex bolts and 3/8" nyloc nuts (See Figure 4, Detail D). Hand tighten.

**NOTE:** If stacking this cart, you may have to loosen and adjust the cart ends (Figure 2), side braces (Figure 3, Detail C), and the tension bars (Figure 4, Detail D) so the next cart sits correctly on top. Retighten.

5. Tighten all bolts.

#### CASTER INSTALLATION INSTRUCTIONS (SWIVEL CASTER SHOWN)

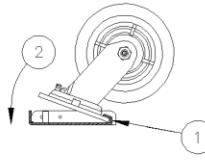

- 1) SLIDE CASTER UNDER TAB.
- 2) ONCE CASTER IS UNDER TAB, PRESS CASTER DOWN OVER THREADED STUDS.
- 3) ADD 5/16" LOCK WASHER & NUT, TIGHTEN.

FIGURE 1

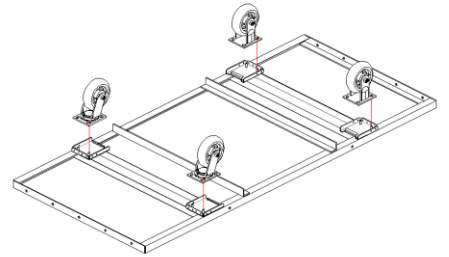

FIGURE 2

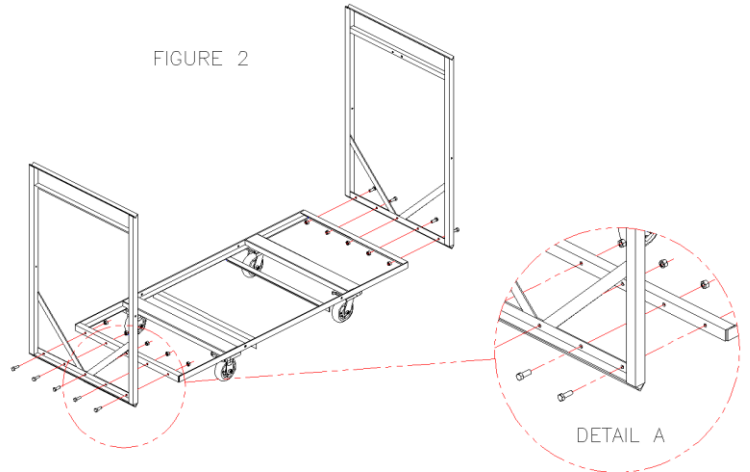

FIGURE 3

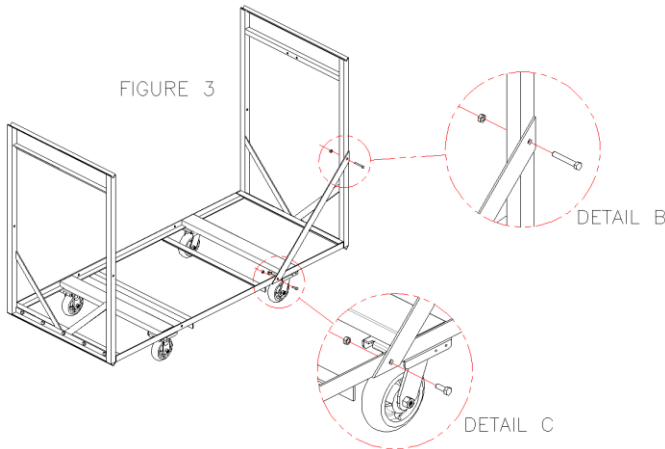

FIGURE 4

