



MITYLITE™

RT Cart-Flat

ASSEMBLY INSTRUCTION SHEET

Supply List

Before beginning cart assembly, ensure that all of the following components and fasteners are included in the package.

Parts:

1. Base Assembly
2. Handle
3. (2) 3/8"-16 X 3/4" Socket Head Bolt

Tools Required:

1. 5/16" Hex Wrench (included)

Notes:

1. These instructions are used for all versions of the RT Flat Cart.
2. All bolts should be kept tight for the cart to function properly and to avoid a potentially dangerous situation.

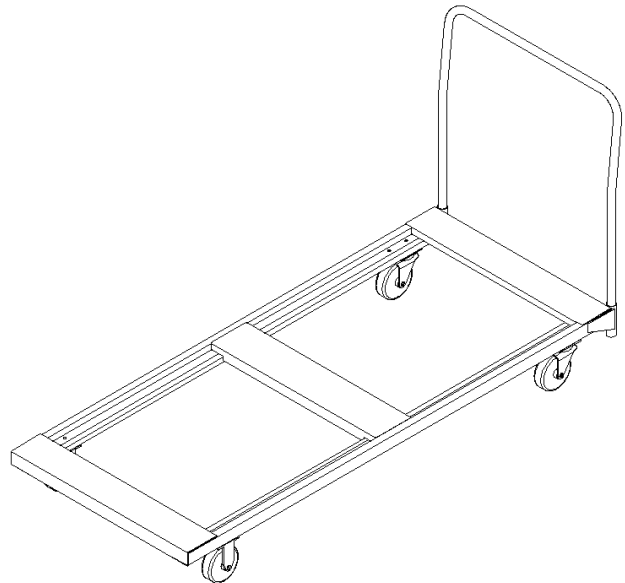
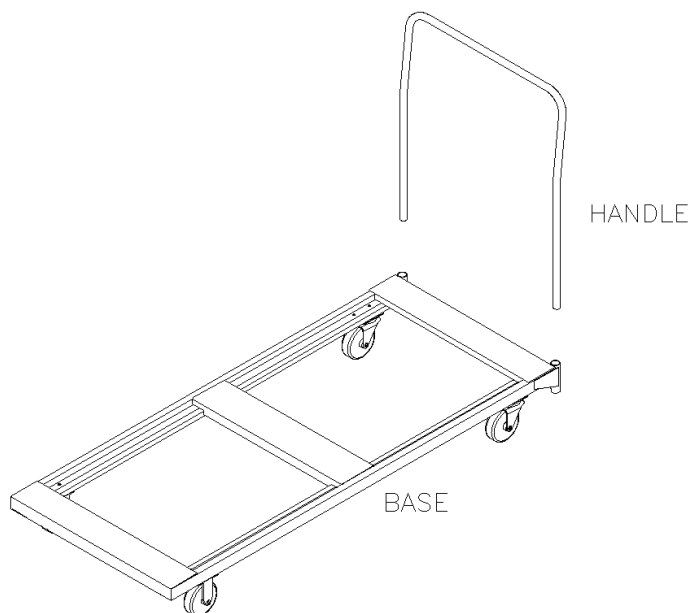
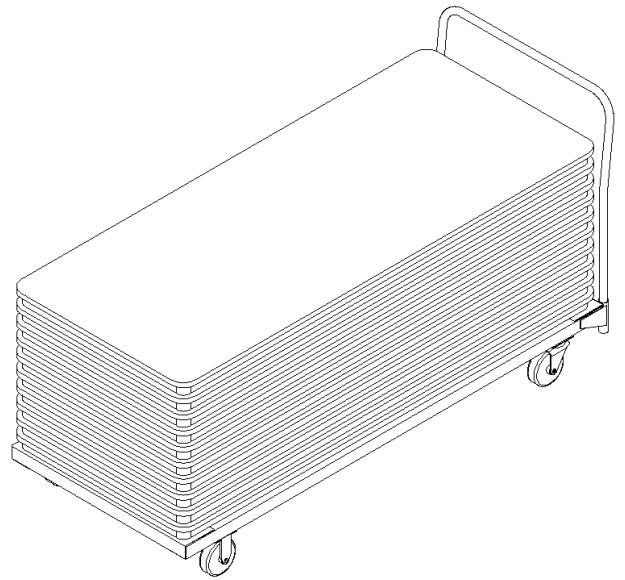

See other side for assembly information



Assembly Instructions

Step:

1. Sit Base on wheels.
2. Insert the handle into the sockets on the end of the Base (See Figure 1). Make sure the handle tilts towards you (See Figure 2).
3. Start the 3/8" X 3/4" socket head bolts into the threaded nut on the sockets (if not already done-See Figure 3). Secure the handle to the Base by using the wrench provided.

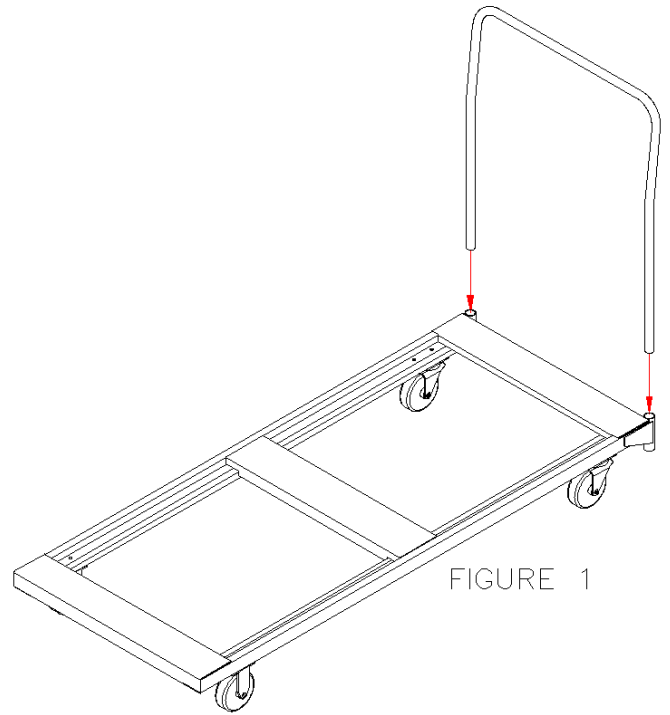

FIGURE 1

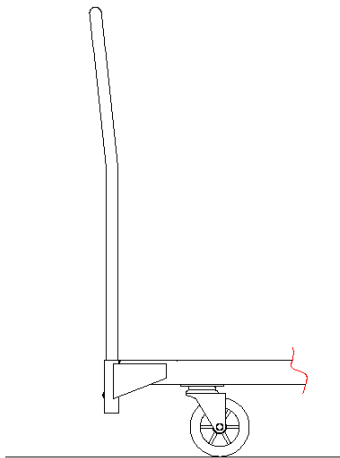

FIGURE 2

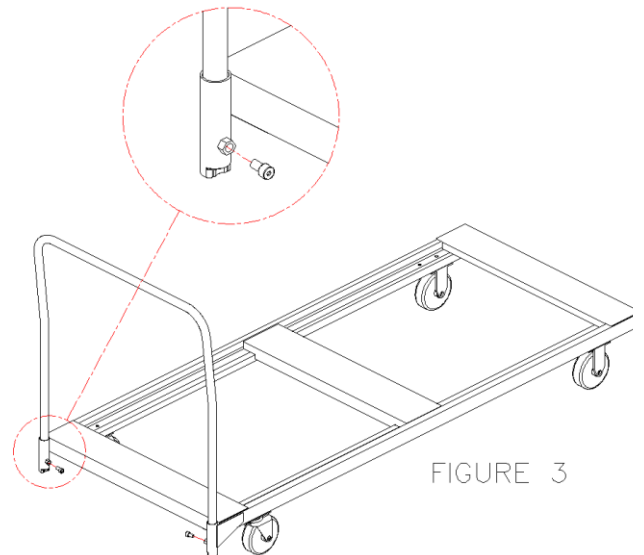

FIGURE 3