



Supply List

Before beginning cart assembly, ensure that all of the following components and fasteners are included in the package.

Parts:

1. Crossbar Assembly
2. Base Assembly
3. End Assembly (2)
4. Hitch (Optional)
5. (1) 3/8"-16 X 1" Hex Bolt
6. (1) 3/8" Nyloc Nut
7. (2) 3/8" Flat Washers
8. (4) 5/16"-18 X 2 1/2" Hex Bolts
9. (8) 5/16" Flat Washers
10. (4) 5/16" Nuts

Tools Required:

1. 1/2" Wrench/Ratchet & Socket (not included)
2. 9/16" Wrench/Ratchet & Socket (not included)

Notes:

1. We recommend at least two people assemble this cart.
2. DO NOT tighten bolts until cart is completely assembled, this allows for adjustment, if necessary.
3. This cart requires a forklift to transport, unless equipped with Hitch (optional).
4. If stacking this cart, **max stack is 2 carts.**
5. Works with MityLite's Comfort Seating Cart-4 Wheel.

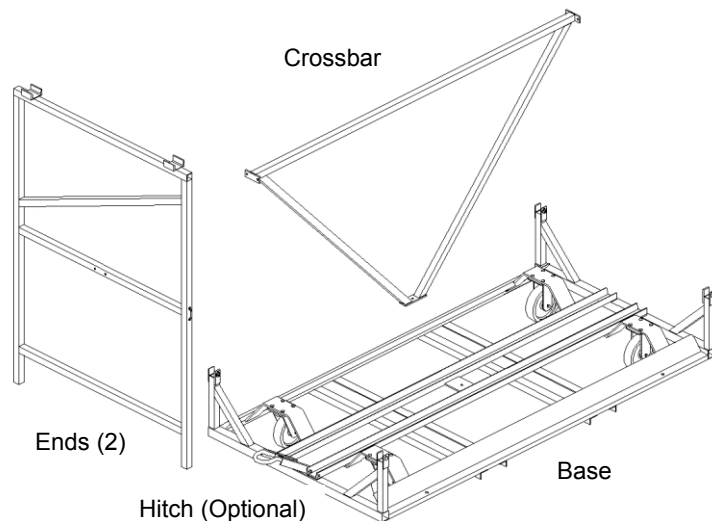
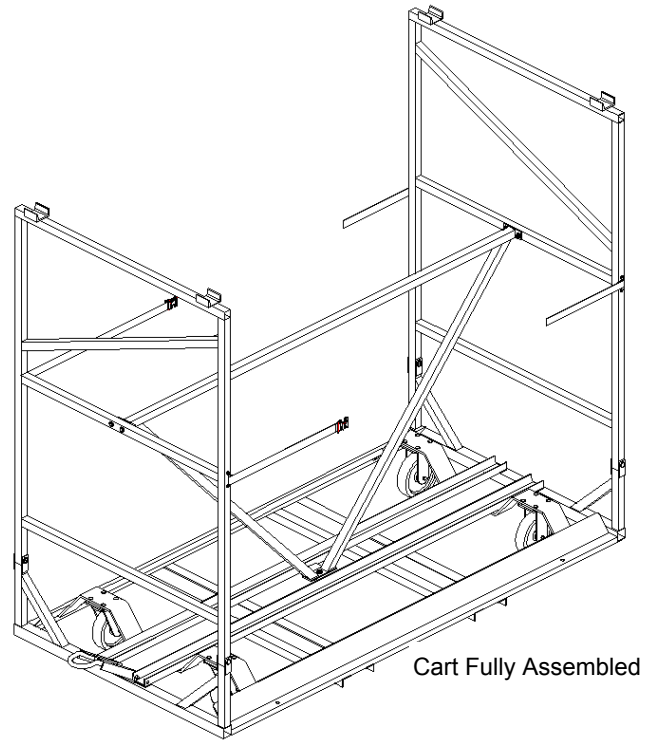

See other side for assembly information

Assembly Instructions

Step:

1. Make sure the cart is on a flat, level surface.
2. To stand ends up, (Figure 1), loosen the 3/8" carriage bolts so the square neck of the bolt is not engaged in the tab (Figure 2, Detail A). This allows you to easily lift and rotate end into position.
3. Once end is upright, push the 3/8" carriage bolt back into the tab and hand tighten.
4. Repeat for other end of the cart.
5. Attach the Crossbar to the Base with the 1" long, 3/8" hex bolt, 3/8" washers, and 3/8" Nyloc nut (Figure 3, Detail B). Hand Tighten.
6. Attach each End to the Crossbar using the 2 1/2" long, 5/16" hex bolt, 5/16" washers, and 5/16" nuts (Figure 4, Detail C). Hand Tighten.
7. Tighten all bolts.

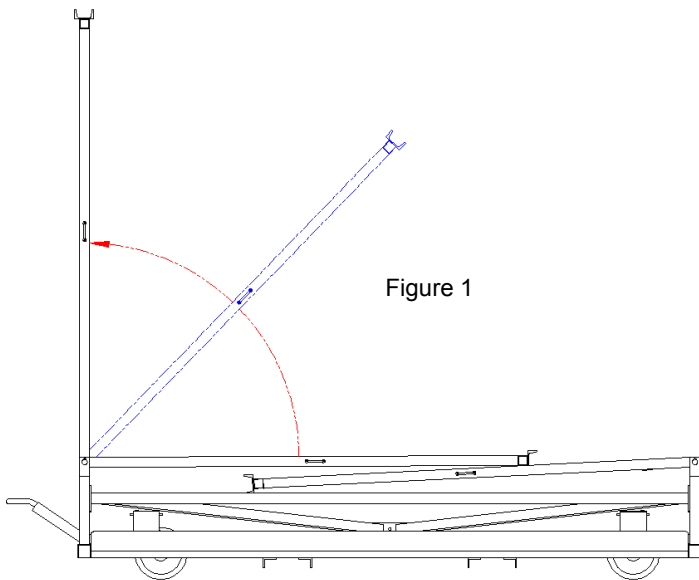

Figure 1

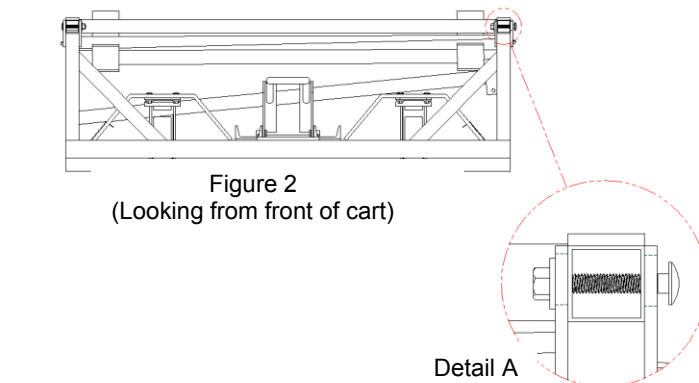

Figure 2
(Looking from front of cart)

Detail A

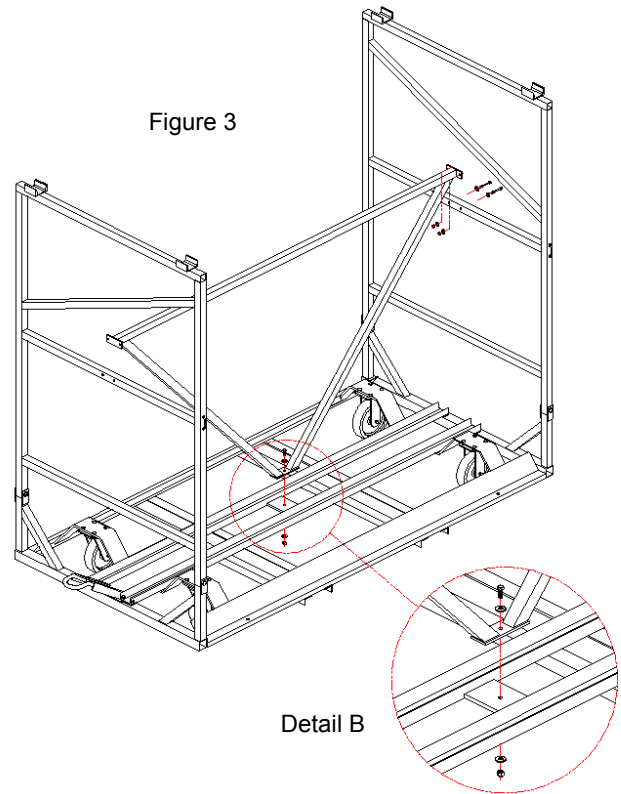

Figure 3

Detail B

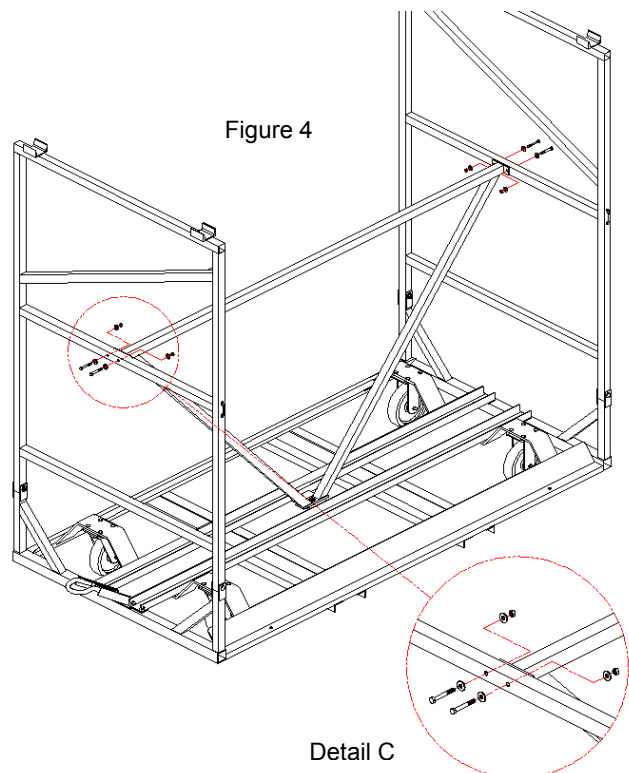

Figure 4

Detail C