



Durable Lightweight Tables & Chairs

Folding Chair Cart-Stacking

ASSEMBLY INSTRUCTION SHEET

Supply List

Before beginning cart assembly, ensure that all of the following components and fasteners are included in the package.

Parts:

1. Tension Rod
2. Base
3. End Frame (2)
4. Side Brace (4)
5. (8) 3/8"-16 X 1" Hex Bolt
6. (12) 3/8" Nyloc Nut
7. (12) 3/8" Flat Washer
8. (4) 3/8"-16 X 2 1/2" Carriage Bolt
9. (24) 5/16"-18 X 1" Carriage Bolt
10. (24) 5/16" Flat Washers
11. (24) 5/16" Nyloc Nuts
12. (2) 6" Fixed Casters
13. (2) 6" Swivel Casters

Tools Required:

1. 1/2" Wrench/Ratchet & Socket (not included)
2. 9/16" Wrench/Ratchet & Socket (not included)

Notes:

1. We recommend at least two people assemble this cart.
2. DO NOT tighten bolts until cart is completely assembled, this allows for adjustment, if necessary.
3. This cart requires a forklift to transport.
4. If stacking this cart, **X-Base is required.**

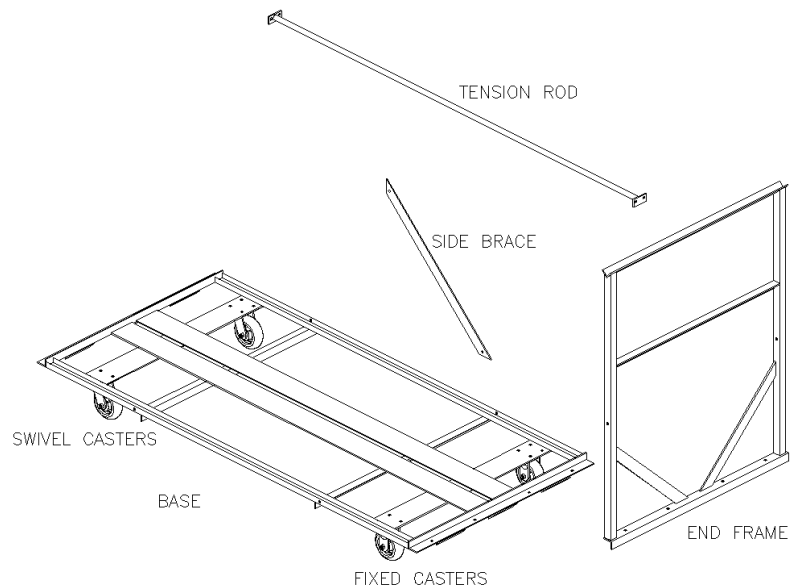
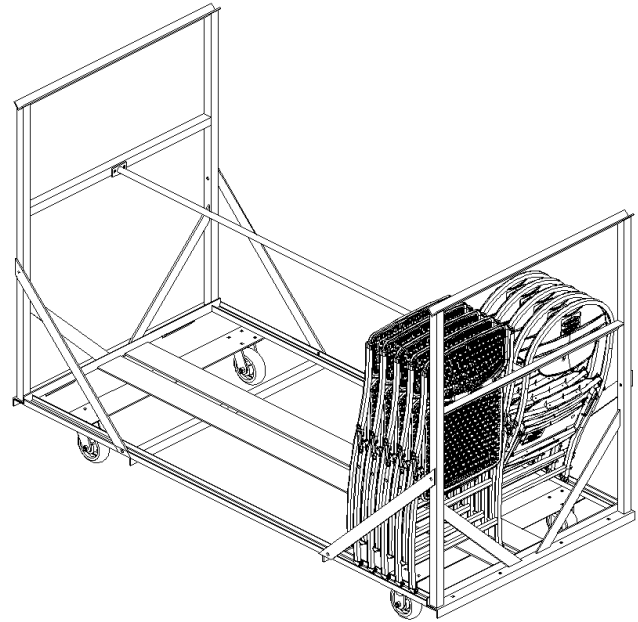

See other side for assembly information

Assembly Instructions

Step:

1. Lay the Base upside down on a flat, level surface. Attach the casters to the Base using the 1" long, 5/16" carriage bolts, washers, and nyloc nuts (See Figure 1, Detail A). Tighten.
2. Turn the Base over so that the casters are on the floor.
3. Attach End Frames using the 1" long, 5/16" carriage bolts, 5/16" washers, and nyloc nuts (See Figure 2, Detail B). Hand tighten. Repeat for other End Frame.
4. Attach the Tension Rod to the End Frames using the 1" long, 3/8" hex bolts and 3/8" washers, and nyloc nuts (See Figure 3, Detail C). Hand tighten.
5. Attach each Side Brace to the End Frame (See Figure 4, Detail D) using the 2 1/2" long, 3/8" carriage bolts and 3/8" washers, and nyloc nuts and each Side Brace to the Base (See Figure 4, Detail E) using the 1" long, 3/8" hex bolts, 3/8" washers, and nyloc nuts. Hand tighten.

NOTE: Make sure the side braces are flush with the edge of the end frame and base. If not, flip the side brace.

NOTE: If stacking this cart, you may need to loosen and adjust the cart ends (Detail B), the tension rod (Detail C), and the side braces (Detail E) so the next cart sits correctly on top.

6. Tighten all bolts.

